

Series 500 Plastic Valve Boxes

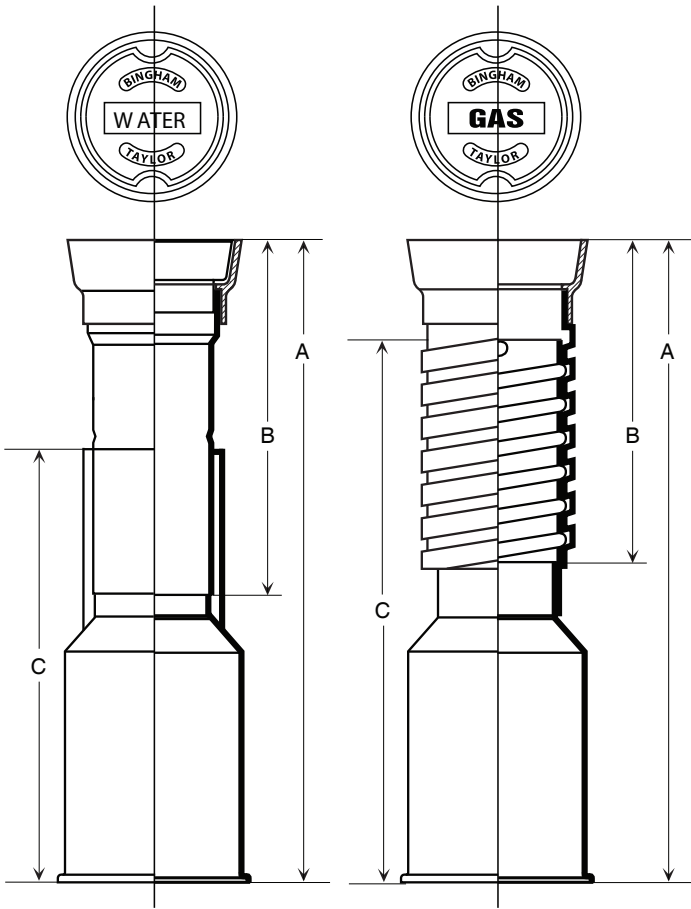

Fig. No. P-500-S
Slide Type Box

Fig. No. P-500-B
Screw Type Box

Fig. No. 500
Series 500 — 5 1/4"
Shaft Plastic Valve Boxes

- Cast iron lid and top rim (standard Buffalo design).
- Cast iron rim permanently bonded to A.B.S. Plastic top tube.
- A.B.S. Plastic top and bottom sections.
- Screw or sliding adjustment.
- Screw type bottom interchangeable with cast iron screw type top section.
- Available in various bell designs to fit assorted valves.
- Extension sections available.
- Specify "Gas" or "Water". Custom lettering at extra charge.
- Paving adapters available, 1" - 4"

Size No. Sliding Type	Size No. Screw Type	Extension Range - A	Length Top-B	Length Bottom-C
P-5461-S	P-18	22"-24"	9"	18"
P-5562-S	P-20	28"-36"	15"	24"
P-5564-S	P-21	40"-48"	15"	36"
P-5662-S	P-21-A	36"-48"	27"	24"
P-5663-S	P-22-A	34"-54"	27"	30"
P-5664-S	P-22	40"-60"	27"	36"
P-5666-S	P-23	52"-72"	27"	48"
P-5766-S	P-24	52"-85"	39"*	48"

* Not available in screw type box.

Please specify top rim style, lid, size number and bell design. (See pages 11 and 12 for selection).

Extension Ordering Table

Sliding Type	Screw Type	Extends Length	Overall Length
P-63-E	P-57	12.0	16.0
P-64-E	P-58	18.0	24.0
P-65-E	P-59	24.0	30.0